

Digital Fundamentals

Tenth Edition

Floyd

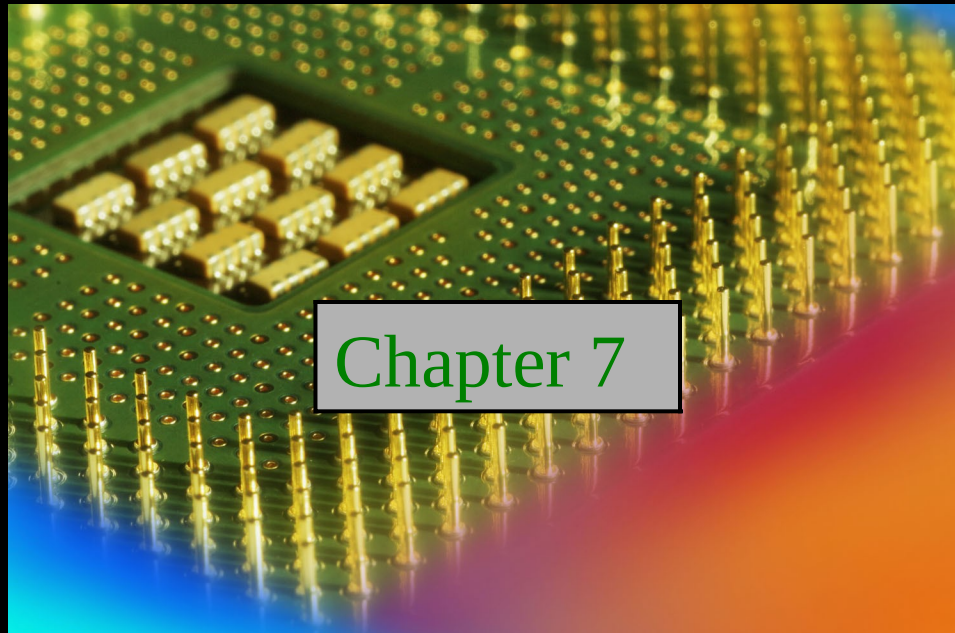

Summary

Latches

A **latch** is a temporary storage device that has two stable states (bistable). It is a basic form of memory.

The S-R (Set-Reset) latch is the most basic type. It can be constructed from NOR gates or NAND gates. With NOR gates, the latch responds to active-HIGH inputs; with NAND gates, it responds to active-LOW inputs.

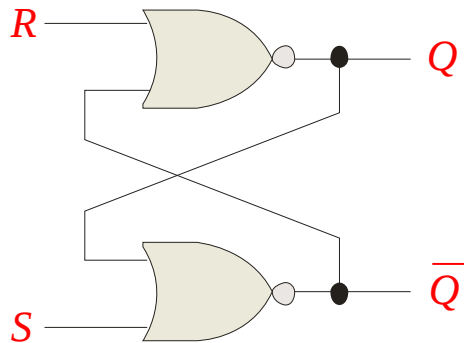

NOR Active-HIGH Latch

Summary

Latches

The active-HIGH S - R latch is in a stable (latched) condition when both inputs are LOW.

Assume the latch is initially RESET ($Q = 0$) and the inputs are at their inactive level (0). To SET the latch ($Q = 1$), a momentary HIGH signal is applied to the S input while the R remains LOW.

To RESET the latch ($Q = 0$), a momentary HIGH signal is applied to the R input while the S remains LOW.

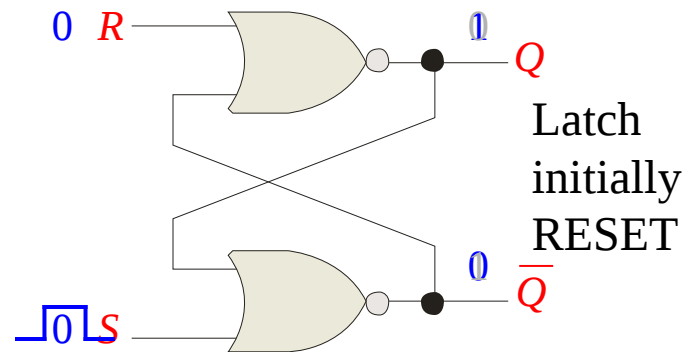

Summary

Latches

The active-LOW \overline{S} - \overline{R} latch is in a stable (latched) condition when both inputs are HIGH.

Assume the latch is initially RESET ($Q = 0$) and the inputs are at their inactive level (1). To SET the latch ($Q = 1$), a momentary LOW signal is applied to the \overline{S} input while the \overline{R} remains HIGH.

To RESET the latch a momentary LOW is applied to the \overline{R} input while \overline{S} is HIGH.

Never apply an active set and reset at the same time (invalid).

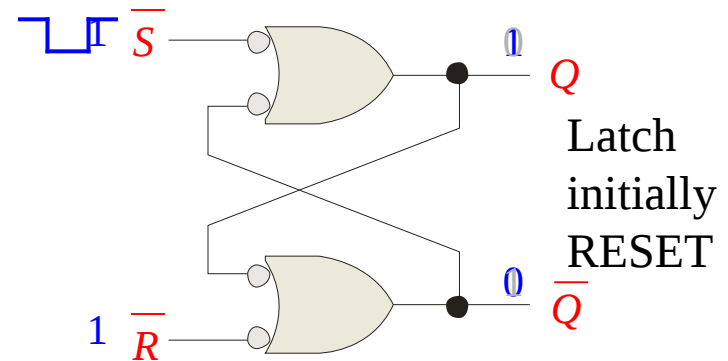

Summary

Latches

The active-LOW \bar{S} - \bar{R} latch is available as the 74LS279A IC.

It features four internal latches with two having two \bar{S} inputs. To SET any of the latches, the \bar{S} line is pulsed low. It is available in several packages.

\bar{S} - \bar{R} latches are frequently used for switch debounce circuits as shown:

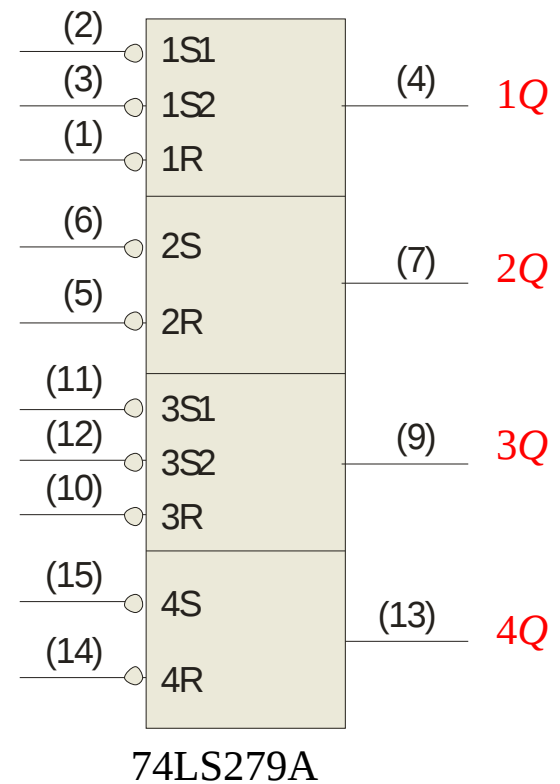
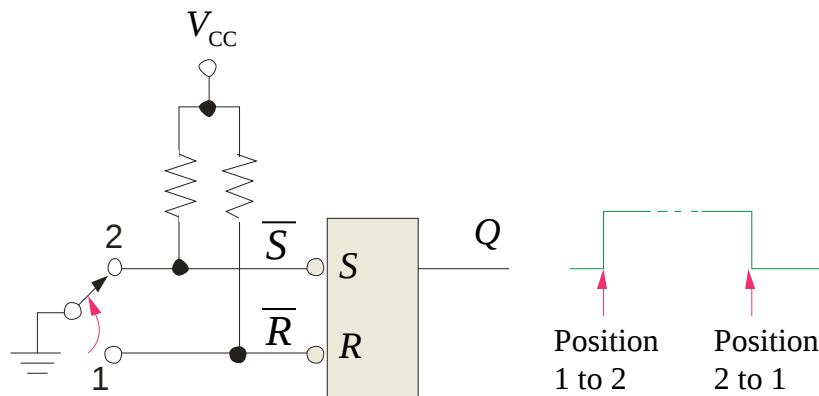

Summary

Latches

A gated latch is a variation on the basic latch.

The gated latch has an additional input, called enable (EN) that must be HIGH in order for the latch to respond to the S and R inputs.

Example Show the Q output with relation to the input signals. Assume Q starts LOW.

Solution Keep in mind that S and R are only active when EN is HIGH.

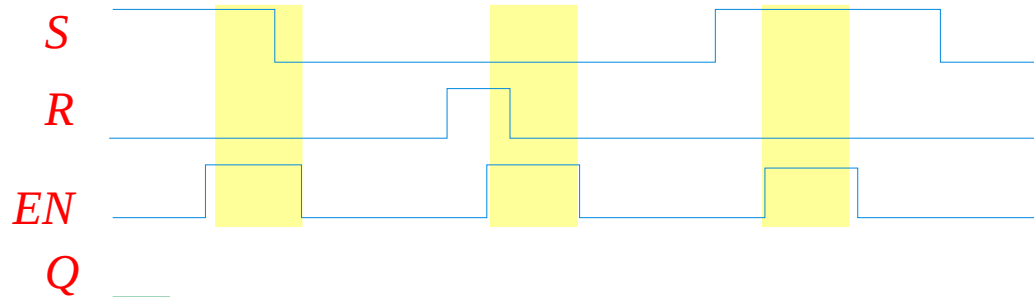
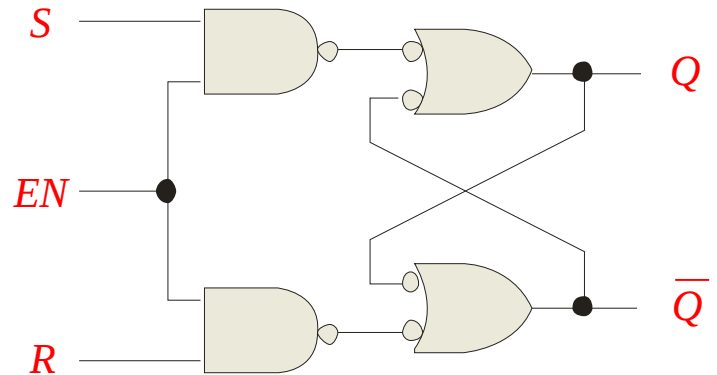

Summary

Latches

The D latch is an variation of the S - R latch but combines the S and R inputs into a single D input as shown:

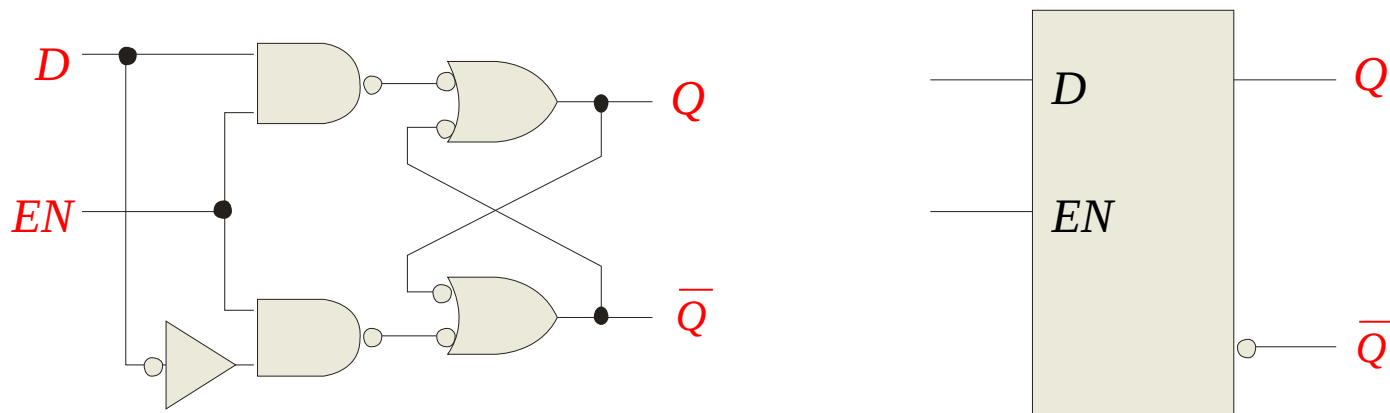

A simple rule for the D latch is:

Q follows D when the Enable is active.

Summary

Latches

The truth table for the D latch summarizes its operation. If EN is LOW, then there is no change in the output and it is latched.

Inputs		Outputs		Comments
D	EN	Q	\bar{Q}	
0	1	0	1	RESET
1	1	1	0	SET
X	0	Q_0	\bar{Q}_0	No change

Summary

Latches

Example

Determine the Q output for the D latch, given the inputs shown.

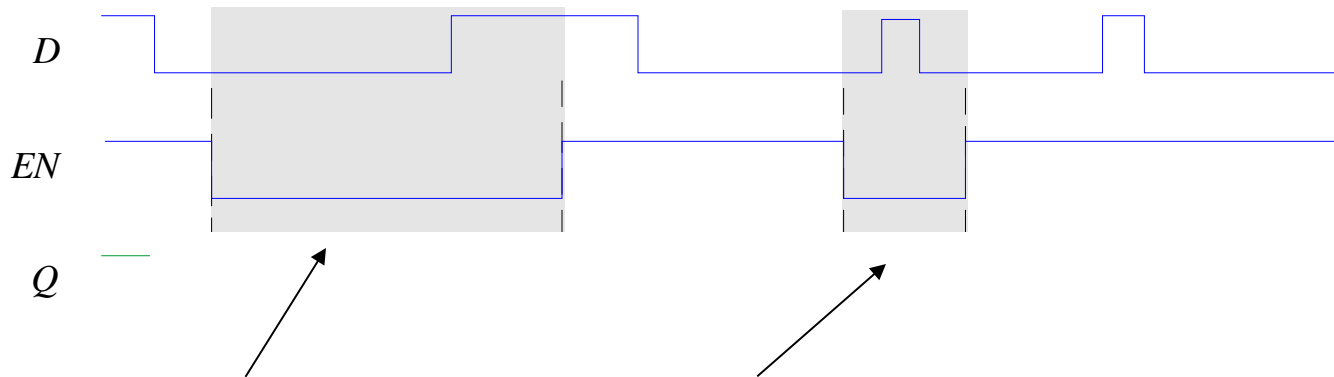
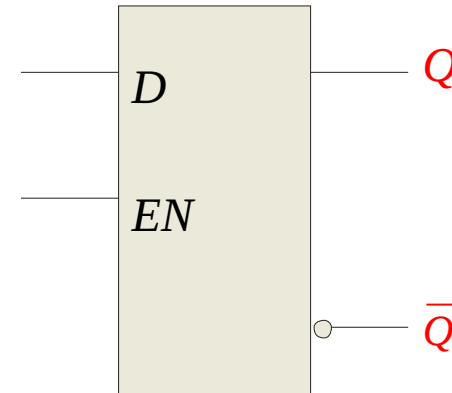

Notice that the Enable is not active during these times, so the output is latched.

Summary

Flip-flops

A flip-flop differs from a latch in the manner it changes states. A flip-flop is a clocked device, in which only the clock edge determines when a new bit is entered.

The active edge can be positive or negative.

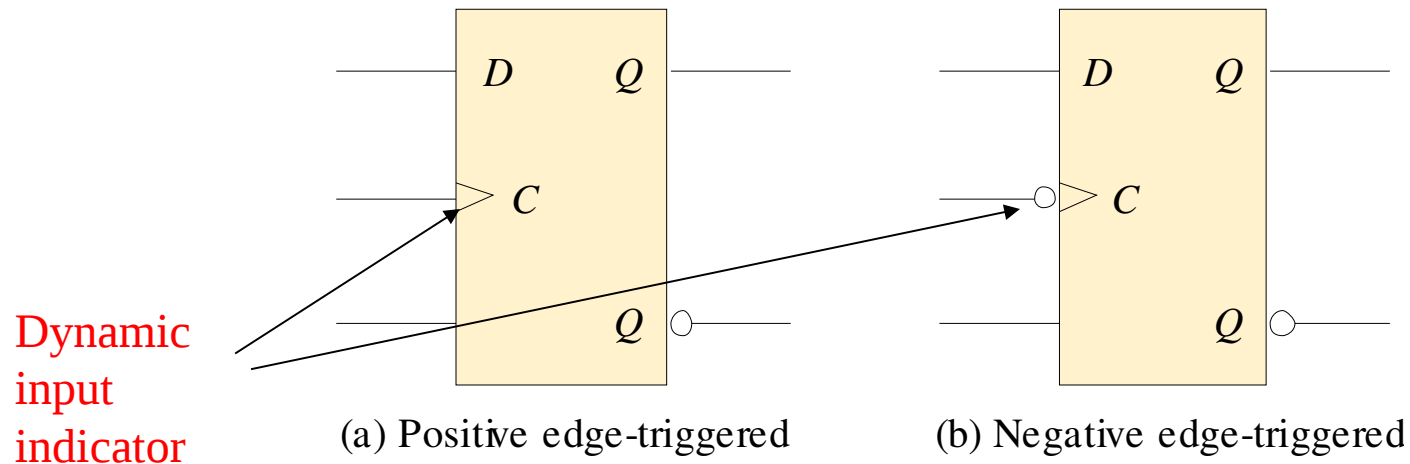

Summary

Flip-flops

The truth table for a positive-edge triggered D flip-flop shows an up arrow to remind you that it is sensitive to its *D* input only on the rising edge of the clock; otherwise it is latched. The truth table for a negative-edge triggered D flip-flop is identical except for the direction of the arrow.

Inputs		Outputs		Comments
<i>D</i>	CLK	<i>Q</i>	\bar{Q}	
1	↑	1	0	SET
0	↑	0	1	RESET

(a) Positive-edge triggered

Inputs		Outputs		Comments
<i>D</i>	CLK	<i>Q</i>	\bar{Q}	
1	↓	1	0	SET
0	↓	0	1	RESET

(b) Negative-edge triggered

Summary

Flip-flops

The J-K flip-flop is more versatile than the D flip flop. In addition to the clock input, it has two inputs, labeled J and K . When both J and $K = 1$, the output changes states (toggles) on the active clock edge (in this case, the rising edge).

Inputs			Outputs		Comments
J	K	CLK	Q	\bar{Q}	
0	0	↑	Q_0	\bar{Q}_0	No change
0	1	↑	0	1	RESET
1	0	↑	1	0	SET
1	1	↑	\bar{Q}_0	Q_0	Toggle

Summary

Flip-flops

Example

Determine the Q output for the J - K flip-flop, given the inputs shown.

Notice that the outputs change on the leading edge of the clock.

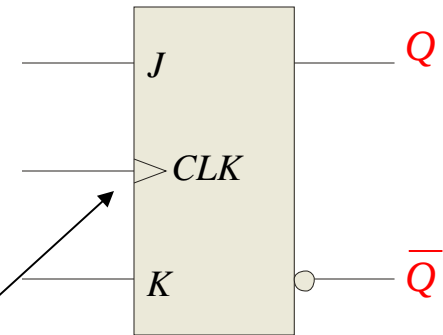

Solution

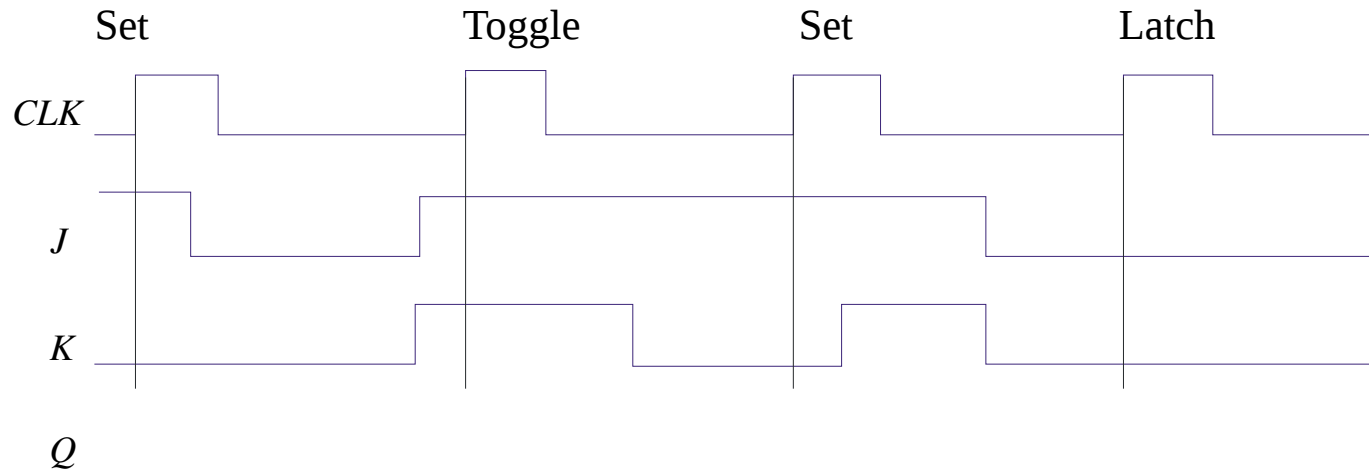

Summary

Flip-flops

A D-flip-flop does not have a toggle mode like the J-K flip-flop, but you can hardwire a toggle mode by connecting \overline{Q} back to D as shown. This is useful in some counters as you will see in Chapter 8.

For example, if Q is LOW, \overline{Q} is HIGH and the flip-flop will toggle on the next clock edge. Because the flip-flop only changes on the active edge, the output will only change once for each clock pulse.

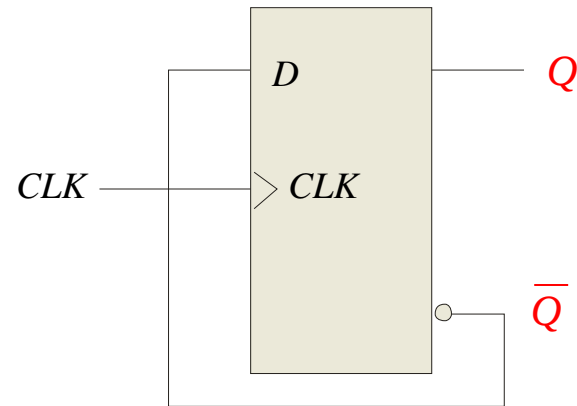

D flip-flop hardwired for a toggle mode

Summary

Flip-flops

Synchronous inputs are transferred in the triggering edge of the clock (for example the D or J - K inputs). Most flip-flops have other inputs that are *asynchronous*, meaning they affect the output independent of the clock.

Two such inputs are normally labeled preset (PRE) and clear (CLR). These inputs are usually active LOW. A J-K flip flop with active LOW preset and CLR is shown.

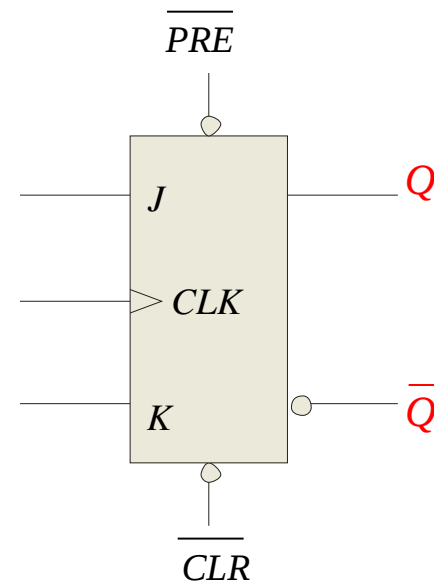

Summary

Flip-flops

Example

Determine the Q output for the J - K flip-flop, given the inputs shown.

Solution

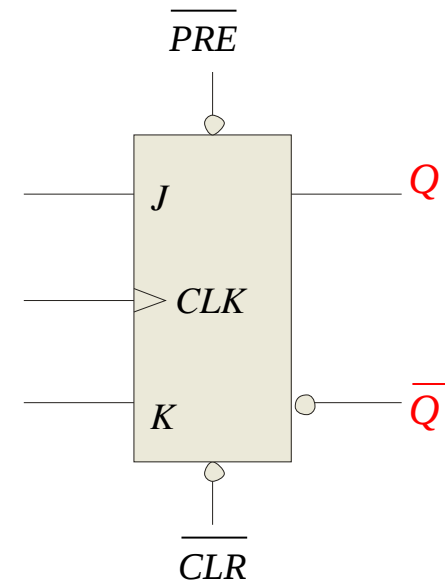
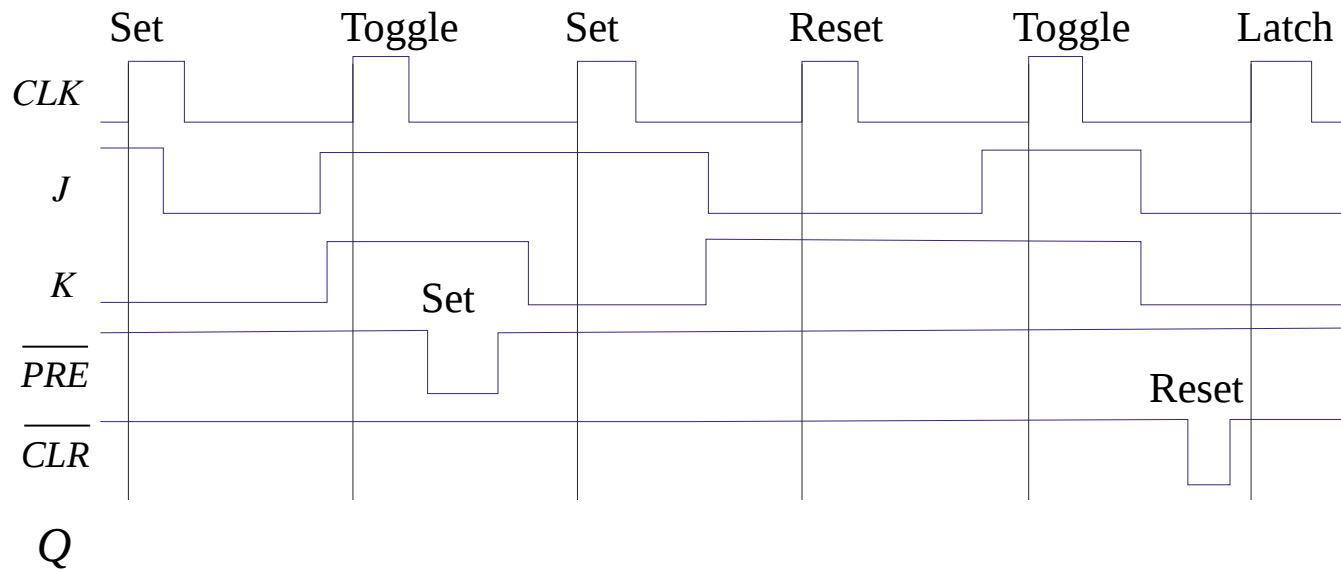

Summary

Flip-flop Characteristics

Propagation delay time is specified for the rising and falling outputs. It is measured between the 50% level of the clock to the 50% level of the output transition.

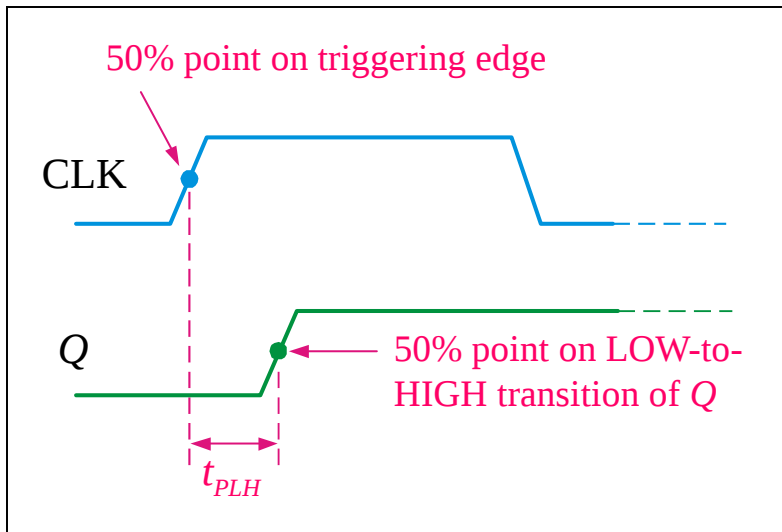

The typical propagation delay time for the 74AHC family (CMOS) is 4 ns. Even faster logic is available for specialized applications.

Summary

Flip-flop Characteristics

Another **propagation delay time** specification is the time required for an *asynchronous* input to cause a change in the output. Again it is measured from the 50% levels. The 74AHC family has specified delay times under 5 ns.

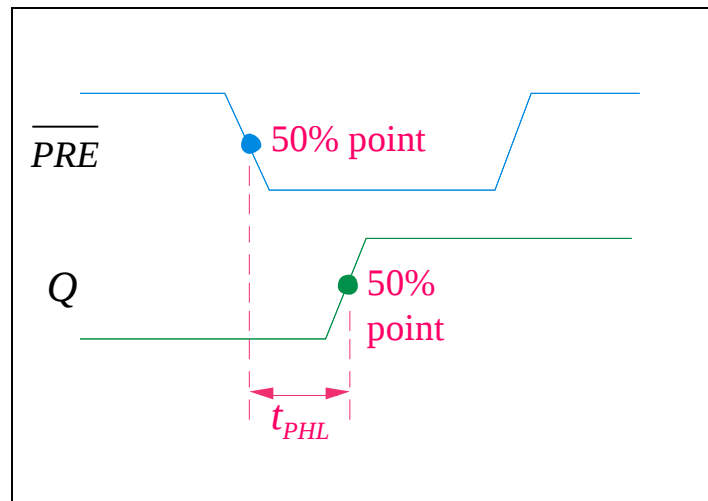

Summary

Flip-flop Characteristics

Set-up time and **hold time** are times required before and after the clock transition that data must be present to be reliably clocked into the flip-flop.

Setup time is the minimum time for the data to be present *before* the clock.

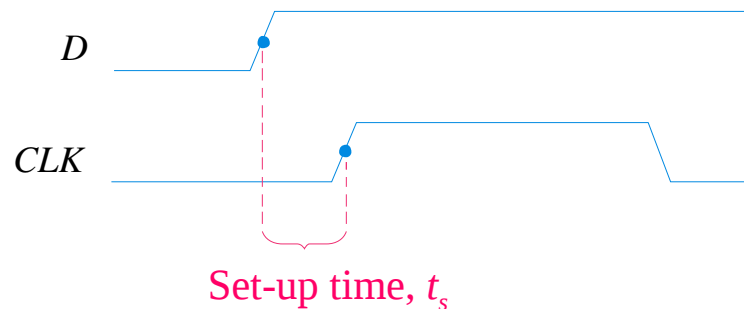

Hold time is the minimum time for the data to *remain* after the clock.

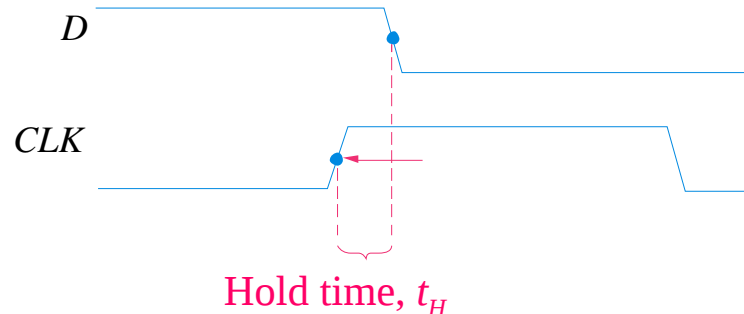

Summary

Flip-flop Characteristics

Other specifications include maximum clock frequency, minimum pulse widths for various inputs, and power dissipation. The power dissipation is the product of the supply voltage and the average current required.

A useful comparison between logic families is the **speed-power product** which uses two of the specifications discussed: the average propagation delay and the average power dissipation. The unit is energy.

Example What is the speed-power product for 74AHC74A? Use the data from Table 7-5 to determine the answer.

Solution From Table 7-5, the average propagation delay is 4.6 ns. The quiescent power dissipated is 1.1 mW. Therefore, the speed-power product is **5 pJ**

Summary

Flip-flop Applications

Principal flip-flop applications are for temporary data storage, as frequency dividers, and in counters (which are covered in detail in Chapter 8).

Typically, for **data storage** applications, a group of flip-flops are connected to parallel data lines and clocked together. Data is stored until the next clock pulse.

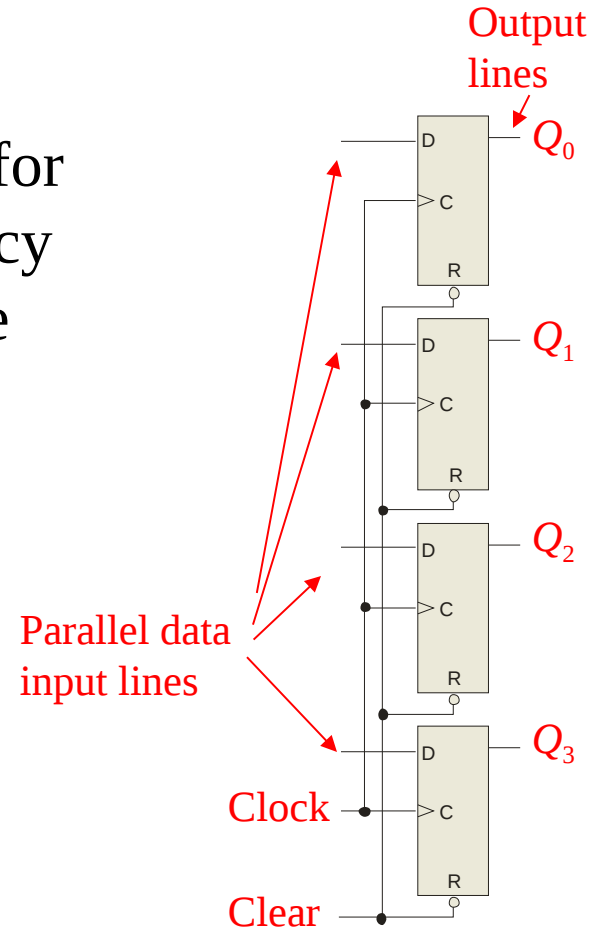

Summary

Flip-flop Applications

For **frequency division**, it is simple to use a flip-flop in the toggle mode or to chain a series of toggle flip flops to continue to divide by two.

One flip-flop will divide f_{in} by 2, two flip-flops will divide f_{in} by 4 (and so on). A side benefit of frequency division is that the output has an exact 50% duty cycle.

Waveforms:

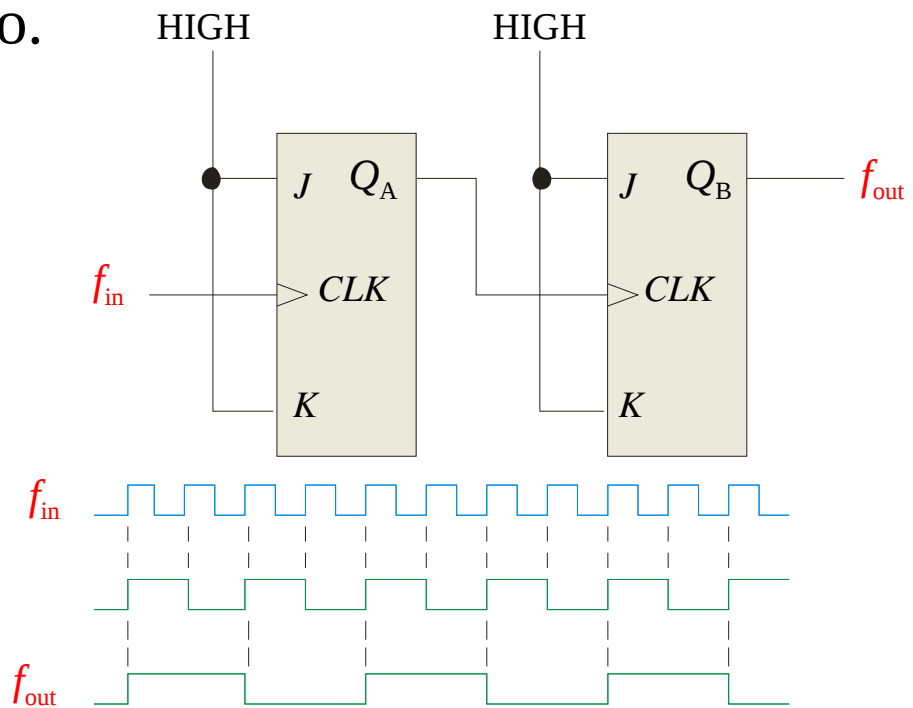

Summary

One-Shots

The **one-shot** or **monostable** multivibrator is a device with only one stable state. When triggered, it goes to its unstable state for a predetermined length of time, then returns to its stable state.

For most one-shots, the length of time in the unstable state (t_w) is determined by an external RC circuit.

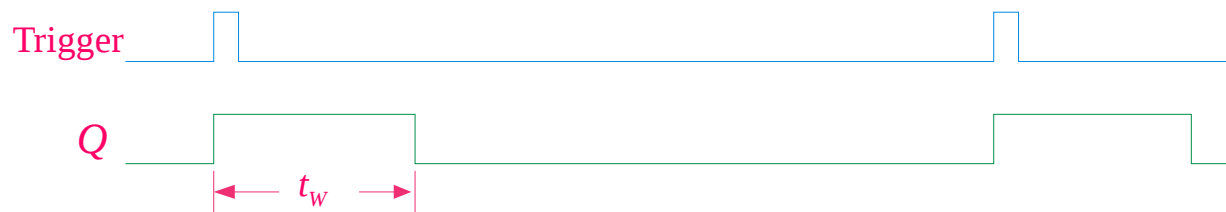
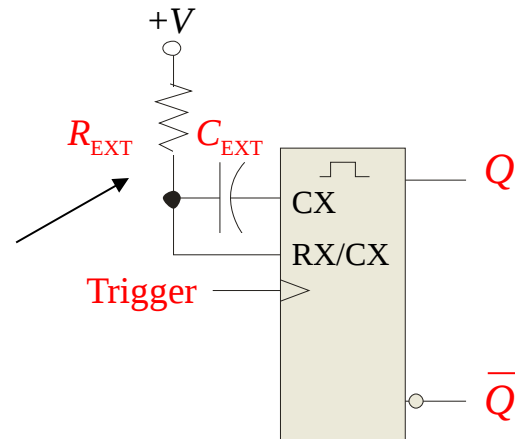

Summary

One-Shots

Nonretriggerable one-shots do not respond to any triggers that occur during the unstable state.

Retriggerable one-shots respond to any trigger, even if it occurs in the unstable state. If it occurs during the unstable state, the state is extended by an amount equal to the pulse width.

Retriggerable one-shot:

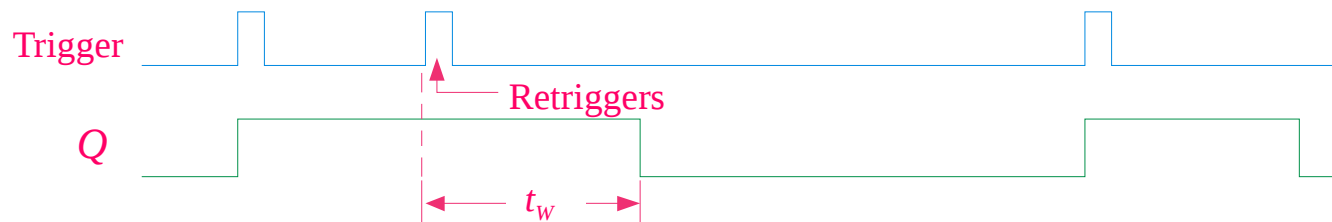

Summary

One-Shots

An application for a retriggerable one-shot is a power failure detection circuit. Triggers are derived from the ac power source, and continue to retrigger the one shot. In the event of a power failure, the one-shot is not triggered and an alarm can be initiated.

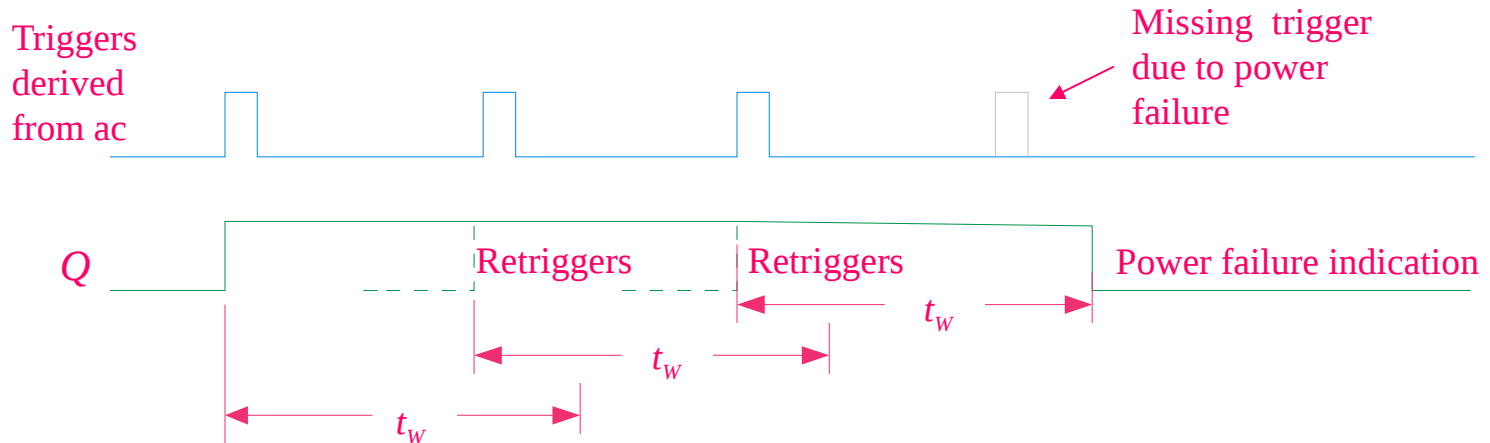

Summary

The 555 timer

The 555 timer can be configured in various ways, including as a one-shot. A basic one shot is shown. The pulse width is determined by R_1C_1 and is approximately $t_w = 1.1R_1C_1$.

The trigger is a negative-going pulse.

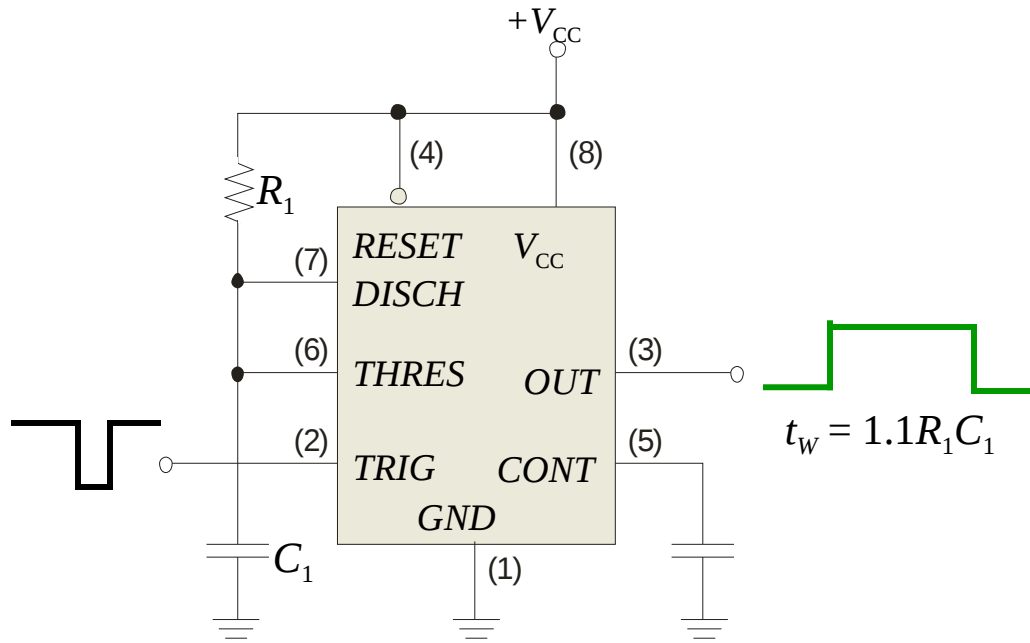

Summary

The 555 timer

Example Determine the pulse width for the circuit

Solution shown.
 $t_w = 1.1R_1C_1 = 1.1(10 \text{ k}\Omega)(2.2 \text{ }\mu\text{F}) = 24.2 \text{ ms}$

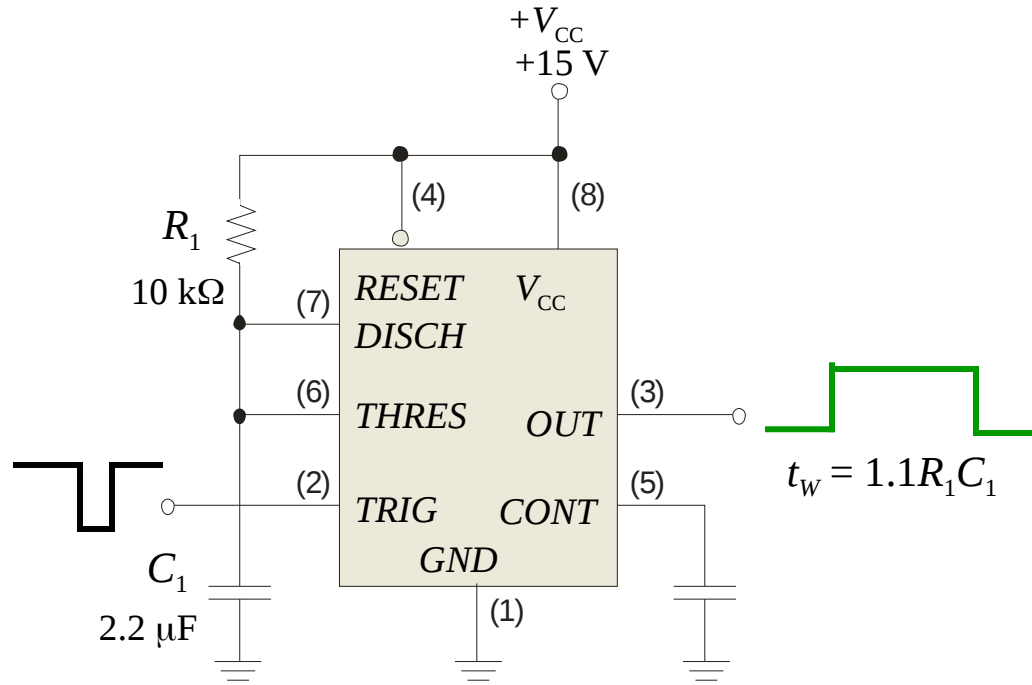

Summary

The 555 timer

The 555 can be configured as a basic astable multivibrator with the circuit shown. In this circuit C_1 charges through R_1 and R_2 and discharges through only R_2 . The output frequency is given by:

$$f = \frac{1.44}{(R_1 + 2R_2) C_1}$$

The frequency and duty cycle are set by these components.

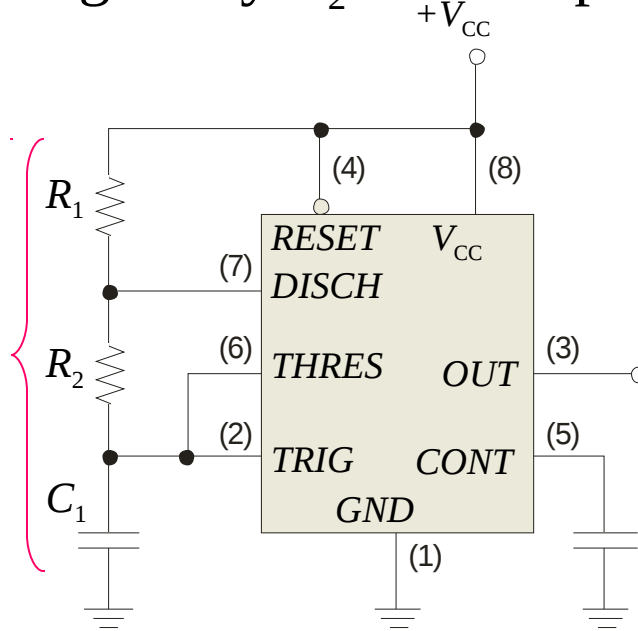

Summary

The 555 timer

Given the components, you can read the frequency from the chart. Alternatively, you can use the chart to pick components for a desired frequency.

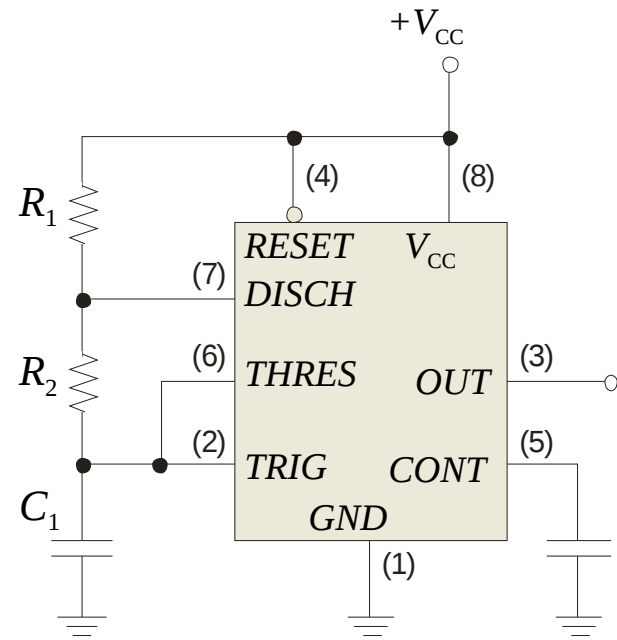
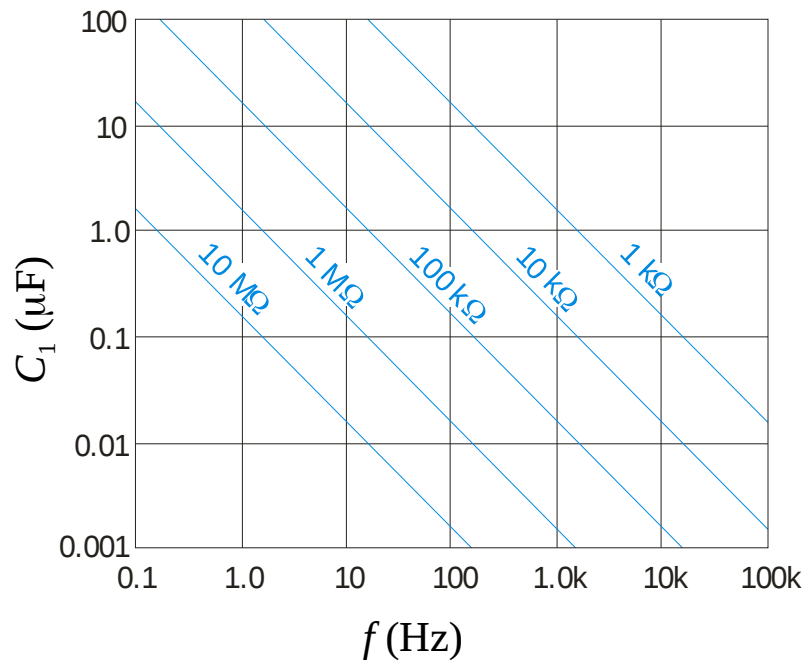

Selected Key Terms

Latch A bistable digital circuit used for storing a bit.

Bistable Having two stable states. Latches and flip-flops are bistable multivibrators.

Clock A triggering input of a flip-flop.

D flip-flop A type of bistable multivibrator in which the output assumes the state of the *D* input on the triggering edge of a clock pulse.

J-K flip-flop A type of flip-flop that can operate in the SET, RESET, no-change, and toggle modes.

Selected Key Terms

Propagation delay time The interval of time required after an input signal has been applied for the resulting output signal to change.

Set-up time The time interval required for the input levels to be on a digital circuit.

Hold time The time interval required for the input levels to remain steady to a flip-flop after the triggering edge in order to reliably activate the device.

Timer A circuit that can be used as a one-shot or as an oscillator.

Quiz.

1. The output of a D latch will not change if
 - a. the output is LOW
 - b. Enable is not active
 - c. D is LOW
 - d. all of the above

Quiz.

2. The D flip-flop shown will
- a. set on the next clock pulse
 - b. reset on the next clock pulse
 - c. latch on the next clock pulse
 - d. toggle on the next clock pulse

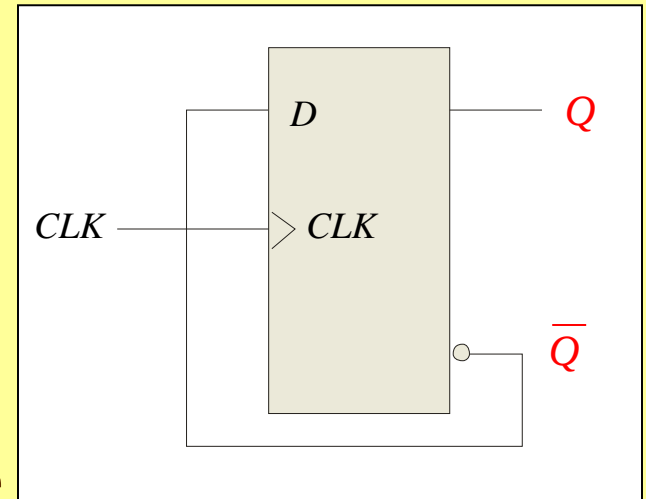

Quiz.

3. For the J-K flip-flop shown, the number of inputs that are asynchronous is

- a. 1
- b. 2
- c. 3
- d. 4

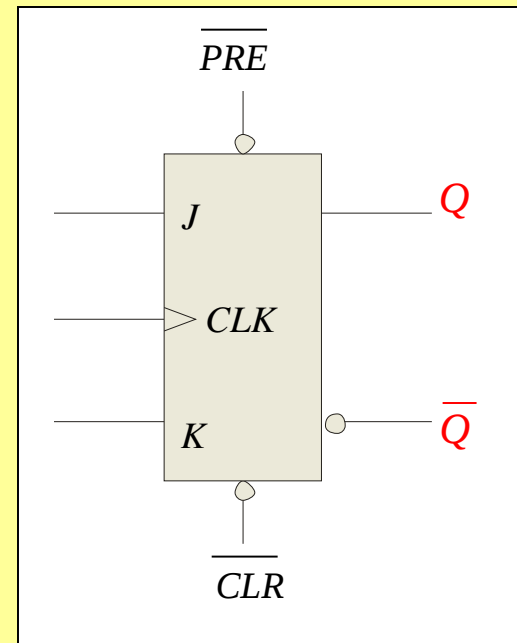

Quiz.

4. Assume the output is initially HIGH on a leading edge triggered J-K flip flop. For the inputs shown, the output will go from HIGH to LOW on which clock pulse?

- a. 1
- b. 2
- c. 3
- d. 4

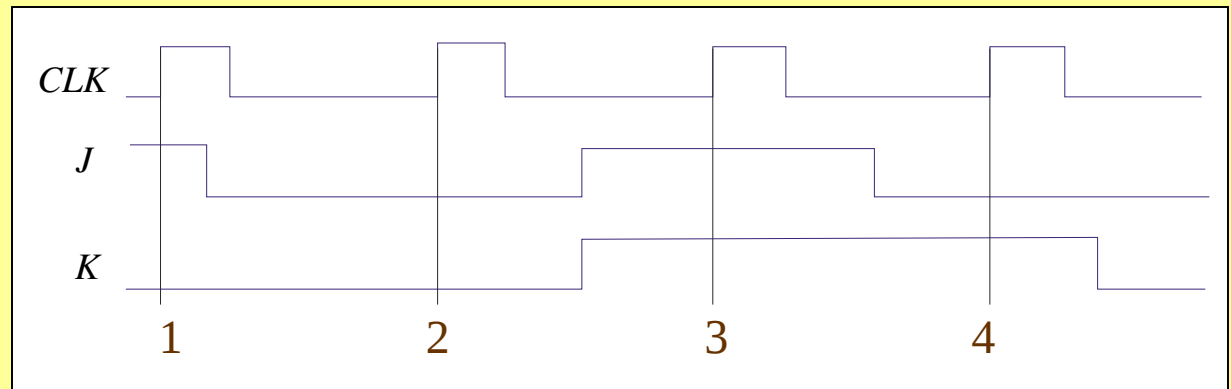

Quiz.

5. The time interval illustrated is called

- a. t_{PHL}
- b. t_{PLH}
- c. set-up time
- d. hold time

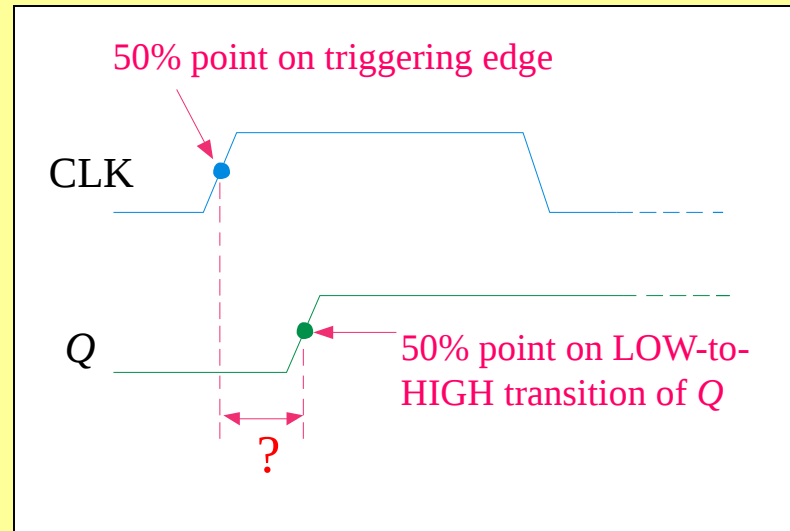

Quiz.

6. The time interval illustrated is called

- a. t_{PHL}
- b. t_{PLH}
- c. set-up time
- d. hold time

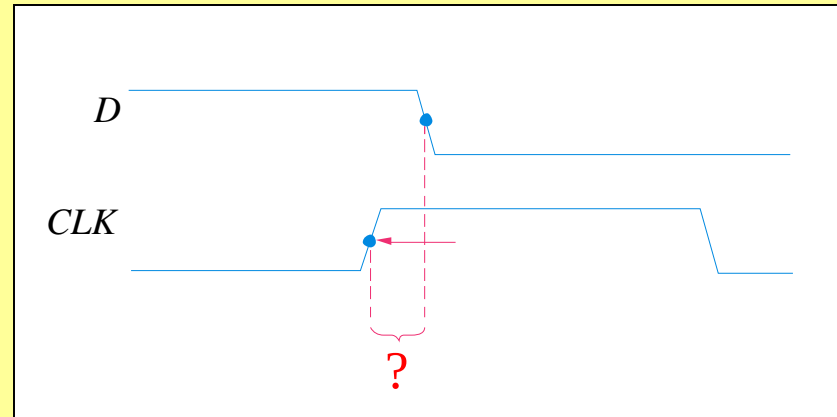

Quiz.

7. The application illustrated is a

- a. astable multivibrator
- b. data storage device
- c. frequency multiplier
- d. frequency divider

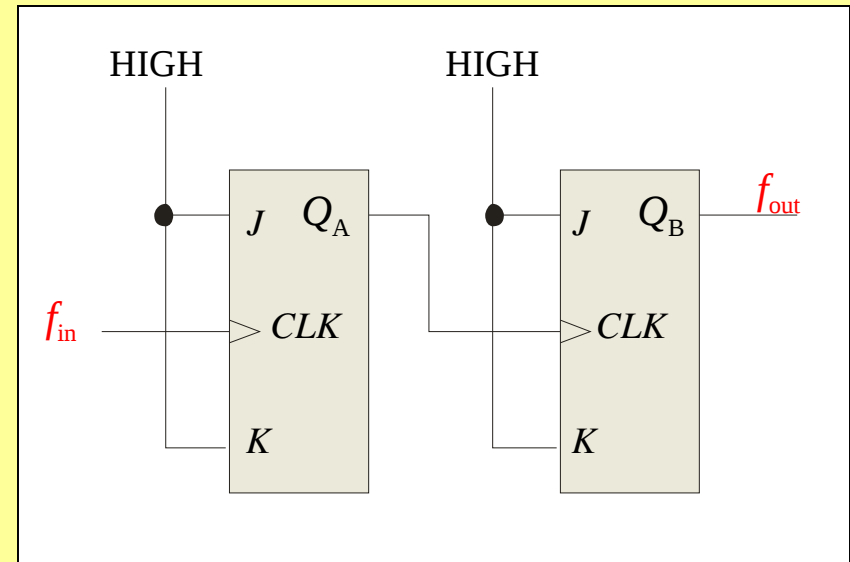

Quiz.

8. The application illustrated is a
- a. astable multivibrator
 - b. data storage device
 - c. frequency multiplier
 - d. frequency divider

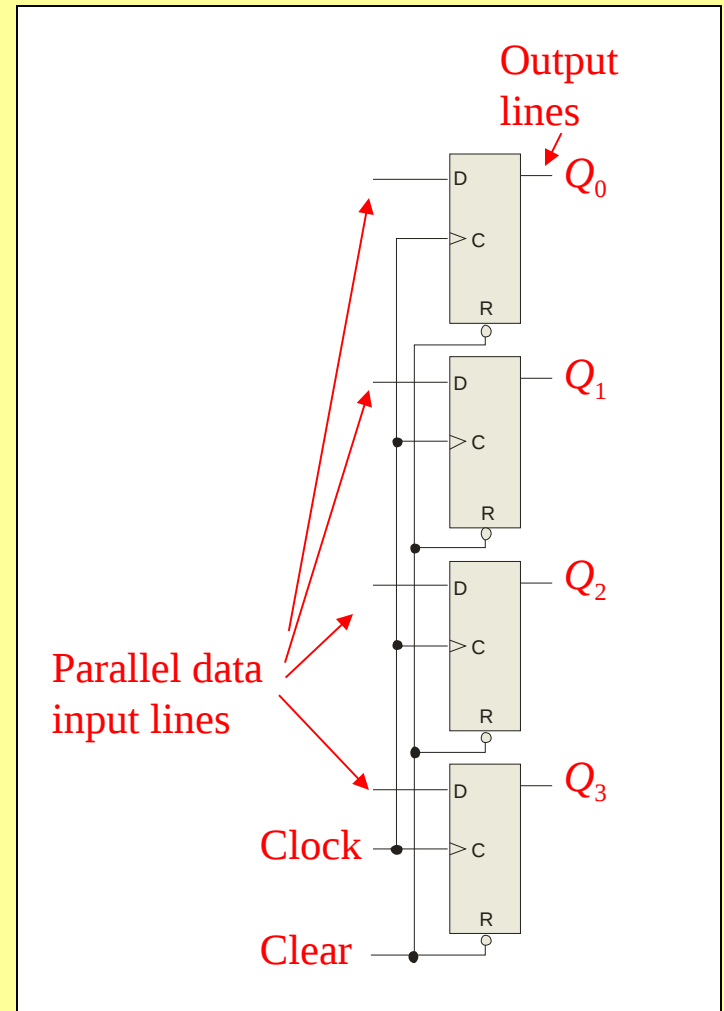

Quiz.

9. A retriggerable one-shot with an active HIGH output has a pulse width of 20 ms and is triggered from a 60 Hz line. The output will be a

- a. series of 16.7 ms pulses
- b. series of 20 ms pulses
- c. constant LOW
- d. constant HIGH

Quiz.

10. The circuit illustrated is a
- a. astable multivibrator
 - b. monostable multivibrator
 - c. frequency multiplier
 - d. frequency divider

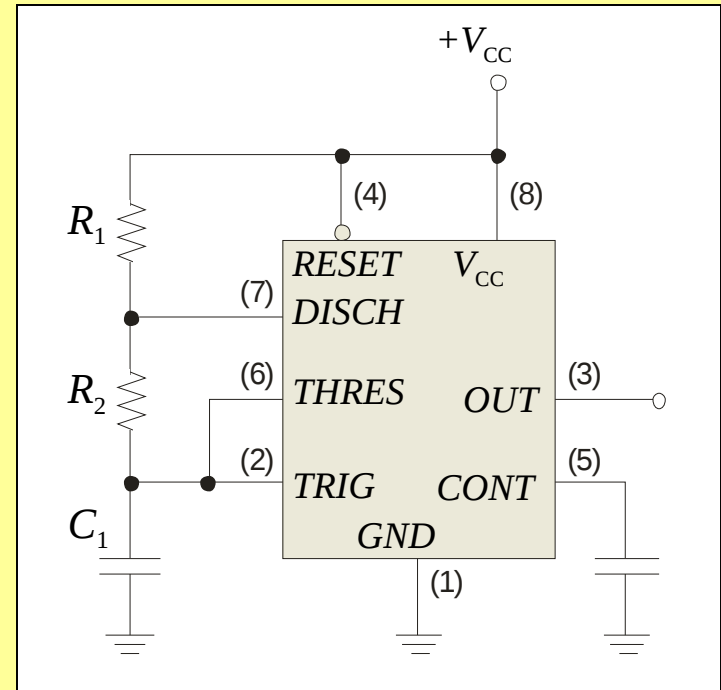

Quiz.

Answers:

- | | |
|------|-------|
| 1. b | 6. d |
| 2. d | 7. d |
| 3. b | 8. b |
| 4. c | 9. d |
| 5. b | 10. a |